

# Engineering Studies

--	--	--	--	--

Centre Number

## Section III

--	--	--	--	--	--	--	--	--

Student Number

20 marks

Attempt Questions 17–18

Allow about 40 minutes for this section

Answer the questions in the spaces provided.

Marks

### Question 17 — Engineering and the Engineering Report (10 marks)

Shade areas are to be added to a major harbourside transport interchange. The interchange is also a popular tourist destination.

- (a) An engineering report is to be produced for the development of shade areas near the interchange. Outline a technical issue and a social issue that would need to be considered in such a report.

2

Technical:

.....

.....

.....

Social:

.....

.....

.....

Question 17 continues on page 28

Question 17 (continued)

(b) Details of a domestic shade area cable tensioning system are given.

4

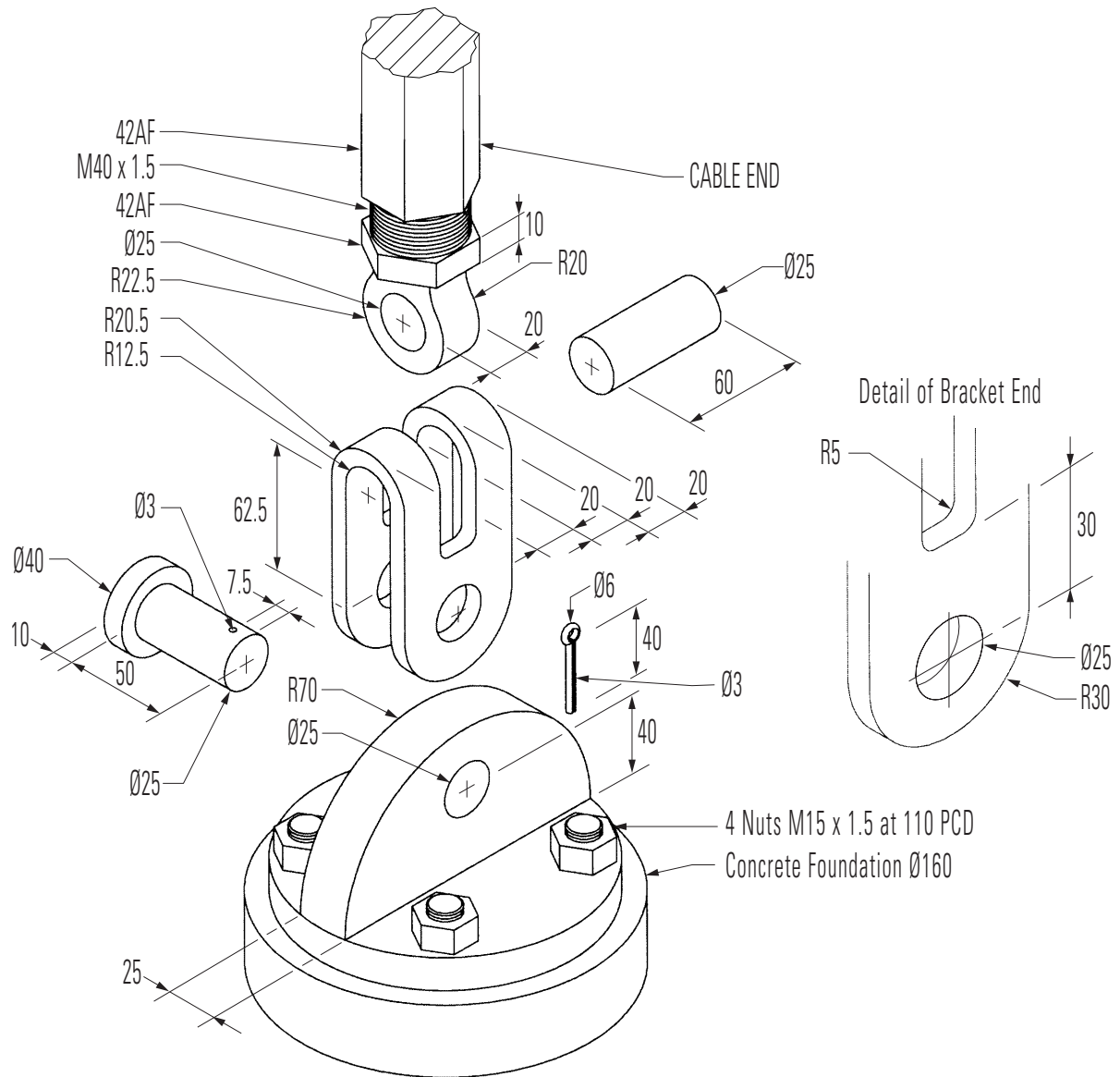

Question 17 continues on page 29

Question 17 (continued)

A partially completed orthogonal sketch of the front and side views of the assembly is shown, drawn to a scale of 1 : 2.

Complete the assembled orthogonal sketch on the grid. Apply AS1100 drawing standards where appropriate. DO NOT show hidden outline. DO NOT dimension.

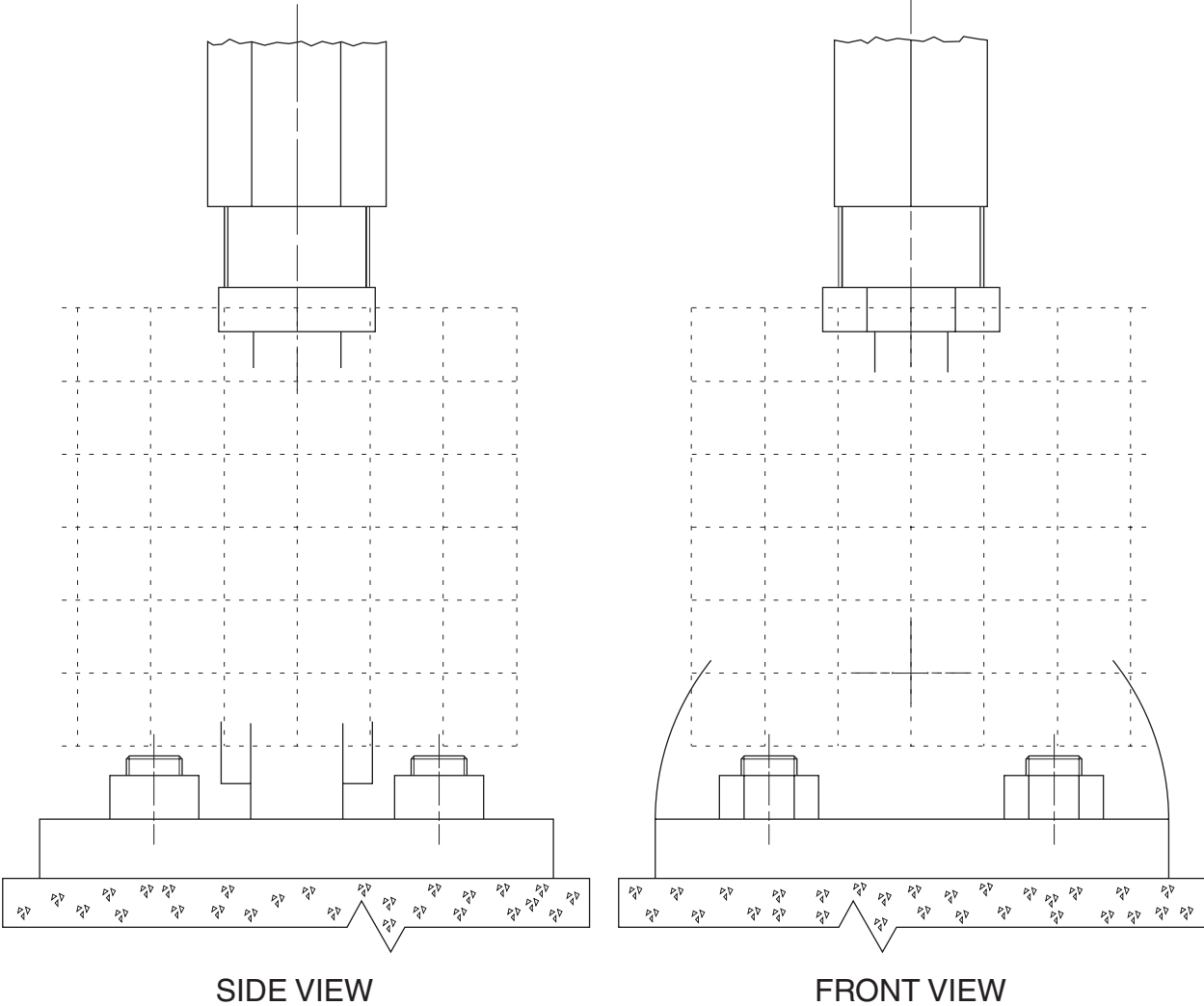

Question 17 continues on page 30

Question 17 (continued)

(c)



- (i) A support for a public shaded area is shown in the photograph. Two types of members, *A* and *B*, are used to distribute the forces created by the weight of the fabric. 2

Explain the structural reasons for the difference in the shape and size of the members.

.....

.....

.....

.....

.....

- (ii) PVC coated polyester fabric is widely used as the cover for shade areas. Discuss how developments in engineering textiles have influenced the design of public shade structures. 2

.....

.....

.....

.....

.....

**End of Question 17**