

Engineering Studies

Section II (continued)

Marks

Question 12 — Civil Structures (10 marks)

(a) A pre-stressed concrete beam is to be used in the construction of a ferry wharf.

The steel tendons used to pre-stress the beam are 18 mm in diameter and 6 metres in length. A force of 30 kN is to be applied to each tendon.

(i) If the Young's modulus for the steel used in the tendons is 210 GPa, calculate the extension of each tendon. 2

$E = \frac{FA}{ae}$ $F = 30 \text{ kN}$ $a = 6 \text{ m}$ $\frac{\pi d^2}{4}$ $\frac{\pi 0.018^2}{4}$ 0.02
 $E = 210$ $E = 210$

Extension = 5250

(ii) Explain TWO benefits of using pre-stressed concrete beams in preference to reinforced concrete beams. 2

they are more stronger as loads have already
 been applied, good corrosion resistance
 better properties

Question 12 continues on page 12

Question 12 (continued)

- (iii) A timber-laminate beam is an alternative to the pre-stressed concrete beam. Discuss TWO factors, other than strength and cost, an engineer would consider in choosing the best option. 3

As the beam is ~~on~~ near the roof corrosion is an important issue so timber laminate is suitable also safety is an important issue an engineer may consider, and also mainly stability.

.....

.....

- (b) The following orthogonal assembly drawing gives details of a pipe support bracket attached to a steel frame, drawn to a scale of 1 : 1. 3

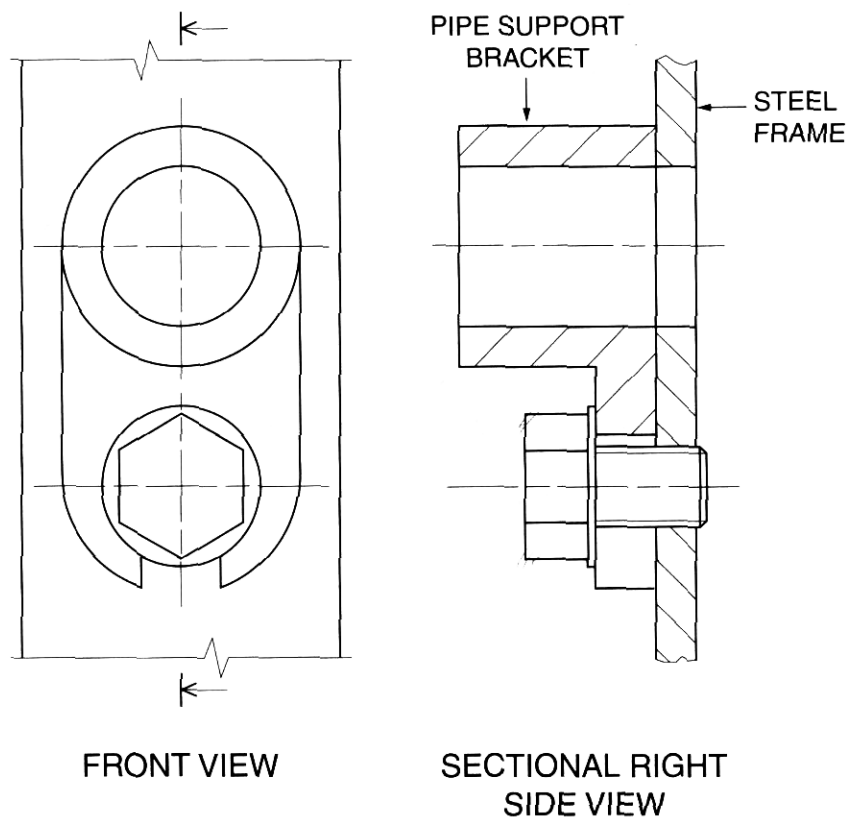

On page 13, sketch a full-size pictorial view of the bracket and frame when viewed from the front. Do NOT include hidden outline. Do NOT section the sketch.

Question 12 continues on page 13

Question 12 (continued)

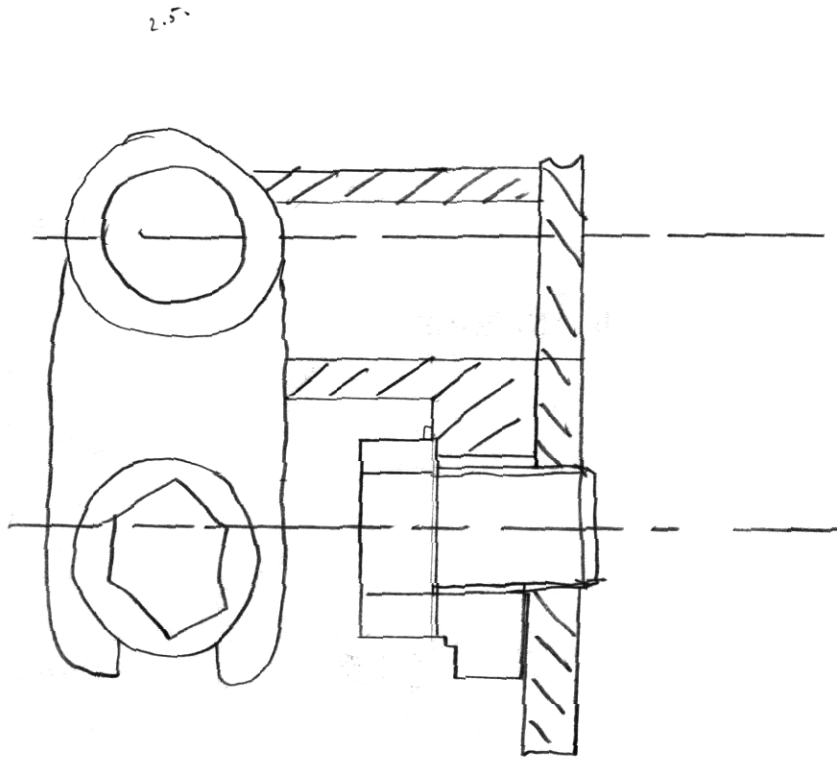

End of Question 12